

WNR Synchro
Tapping Holders



同步攻牙刀把



WNR Synchro Tap Holders (Minimum axial length compensation)

WNR 同步攻牙刀把 (軸向微量伸縮)



Pat.

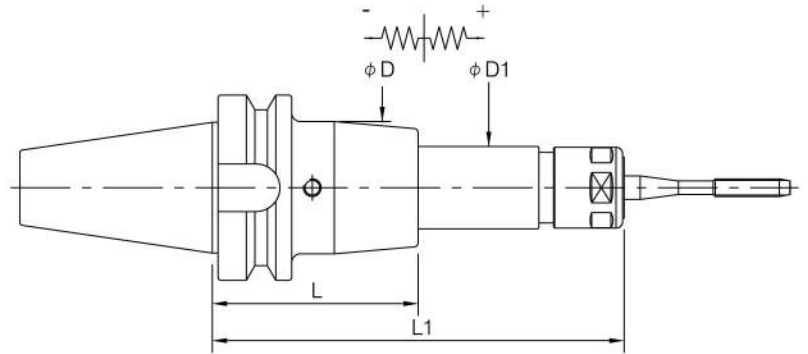

Part No. 規格	Tapping Range 攻牙範圍	ϕD	$\phi D1$	L	L1	Collets 彈性筒夾
BT30-WNR10-100	M2 ~ M12	45	28	65	100	NR10-Exxx -Txxx
-135					135	
-170					170	
BT40-WNR10-105				70	105	
-140					140	
-175					175	
BT50-WNR10-125				90	125	
-160					160	
-195					195	

Features of Synchronization Tap Holders:

- Unique feature can absorb the pitch difference between the tap and spindle when using rigid tapping cycle to minimize thrust load. (compensation of the synchronization error)
- Reduction of the pressure on the tap flanks.
- Higher life of the taps.
- Better threading quality.
- Unique structure suitable for long-term tapping.
- Suitable for tapping and roll forming machines with synchronized feed (speed / feed synchronization).
- With through coolant hole.

同步攻牙刀把之特色：

- 優異的設計，在剛性同步攻牙時，微量伸縮可吸收螺絲攻節距與主軸轉數之間的誤差。
- 減少螺絲攻之切刃邊所受壓力。
- 增加螺絲攻使用壽命。
- 提升攻牙精度。
- 獨特的內部構造，耐長期使用。
- 適用於有「同步攻牙」功能之CNC機器。
- 可中心出水。

WNR Modular Tap Holder Main Shanks

WNR 模組化刀把本體

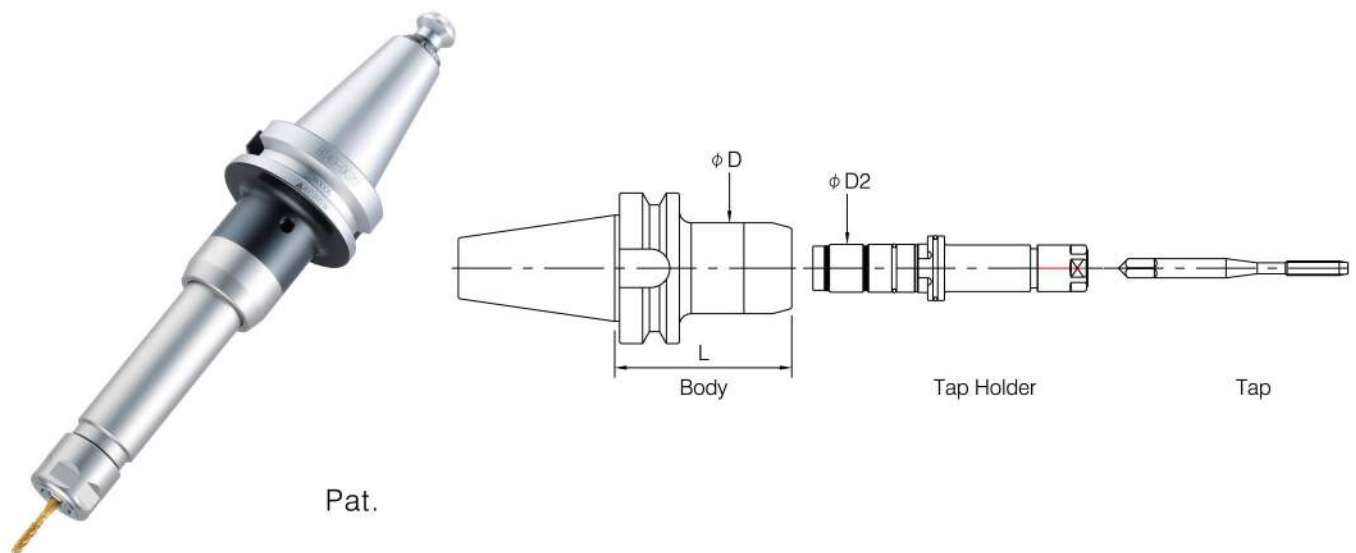

Pat.

Part No. 規格	ϕD	$\phi D2$	L
BT30-WNR-20-070	38	20	70
BT40-WNR-20-075			75
BT50-WNR-20-090			90

WNR Modular Tap holders (Minimum axial length compensation)

WNR 模組化絲攻夾持柄 (軸向微量伸縮)

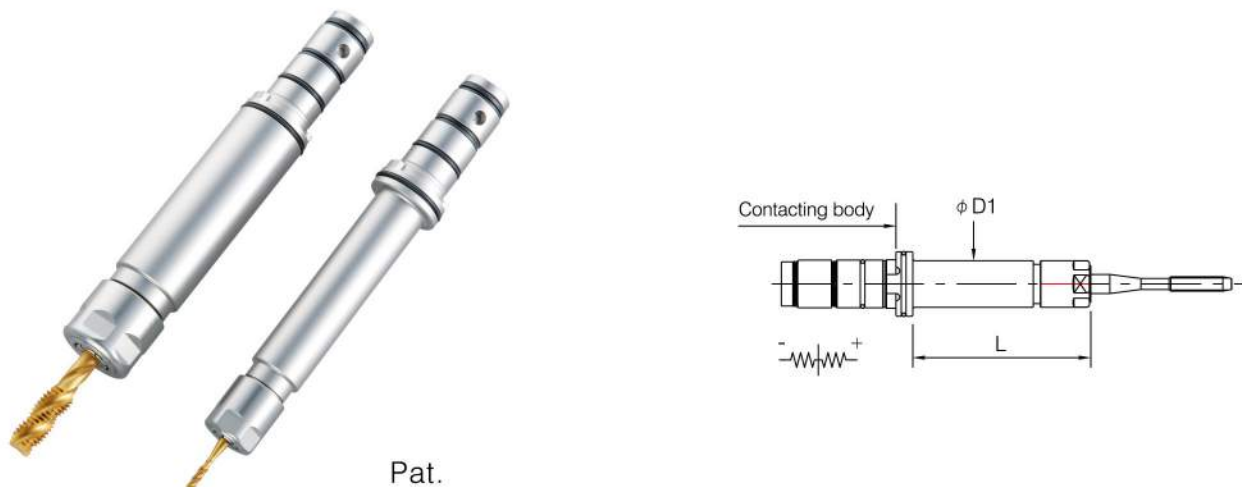

Pat.

Part No. 規格	Tapping Range 攻牙範圍	$\phi D1$	L	Collets 彈性筒夾
S20T-WNR06-030	M2 ~ M6	19.5	30	NR06-Exxx -Txxx
-070			70	
-100			100	
-150			150	
S20T-WNR10-030	M2 ~ M12	27	30	NR10-Exxx -Txxx
-070			70	
-100			100	
-150			150	

Accessories:

附件:

	Part No. 規格	Part No. 規格			
	NR06AA-E030	NR10AA-E030			
	-E040	-E040			
	-E050	-E050			
	-T055	-T055			
	-T060	-T060			
		-T061			
		-T062			
		-T070			
		-T080			
	-T085				
	NR-WD Nuts NR-WD 螺帽				
	Part No. 規格	M	φD	H	L
	NR06WD	M15.5*1.0P	19.5	18.0	21
	NR10WD	M21.5*1.0P	27.5	25.4	24
	Part No. 規格				
	A	B	W	Nuts 適用螺帽	
	W-NR06WD	32	95	18	NR06WD
	W-NR10WD	52	170	1"	NR10WD
<p>Pat.</p>  <p>Attaching & Detaching Collet 裝拆筒夾方法</p>	NR Collet Extractors NR 筒夾裝取器				
	Part No. 規格	Collets 適用筒夾			
	NR06E	NR06			
	NR10E	NR10			



Acrow Machinery Mfg. Co., Ltd.
丸榮機械股份有限公司

No. 9-2, Lane 301, Fong Chou Road, Sheng Kang District,
Taichung City 42945, Taiwan.

42945 台中市神岡區豐洲路301巷9-2號

Tel: +886-4-2520-6812, 2526-0239 Fax: +886-4-2527-9981

E-mail: acrow@ms31.hinet.net, acrow.tool@msa.hinet.net

http://www.acrow-tools.com.tw

